

# Continuous Load Current Mode Analysis of Phase-Controlled AC to DC Converters.

C.U. Ogbuka, M.Eng.\* and M.U. Agu, Ph.D.

Department of Electrical Engineering, University of Nigeria, Nsukka, Nigeria.

E-mail: [ucogbuka@yahoo.com](mailto:ucogbuka@yahoo.com)\*  
[drmarcelaqu@yahoo.co.uk](mailto:drmarcelaqu@yahoo.co.uk)

## ABSTRACT

In this paper, an insightful analysis of controlled AC to DC converters operating under continuous load current mode is presented. The midpoint converter, as the basic building block of other AC to DC converter application circuits, is first analyzed in positive and negative conversion modes. The full bridge converter, fully controlled, is shown to comprise a positive and negative midpoint converter sharing a common AC input and differentially supplying a common output load. The analysis results can be used to predict the output performance of any standard phase controlled converter application circuit with any given number of AC input phases and/or output pulses under continuous load current. The software for simulation is Ansoft SIMPLORER®.

(Keyword: AC to DC converter, continuous load, current mode, midpoint, full bridge)

## INTRODUCTION

AC to DC converters are widely applied industrially, commercially, and domestically. The AC to DC converter changes AC input voltage/current to an output with unidirectional current. The conversion can be controlled or uncontrolled. When uncontrolled, the switching semiconductor used is the diode. When controlled, the switching semiconductor is the three phase terminal thyristor or transistor. The thyristor is preferred because of the nature of the AC input with which thyristor turn-off can be effected.

The AC to DC converter are of two basic configurations:

- a) The midpoint AC to DC converter
- b) The full bridge AC to DC converter

## THE FULLY CONTROLLED MIDPOINT CONVERTERS

The fully controlled AC to DC midpoint converters, especially the two and the three pulse types, constitute the primary units for configuring or realizing other forms of AC to DC converters. The midpoint converter has two forms of connection namely: the positive (forward connected) converter and the negative (reverse connected) converter. In phase control, the control parameter is control delay angle whose zero point is given by:

$$\omega t|_{\alpha=0} = \pi \left( \frac{1}{2} - \frac{1}{N_p} \right) \quad (1)$$

Where  $N_p$  is the converter output pulse number and the control signal length for continuous gating is  $\frac{2\pi}{N_p}$ . The circuit configurations for two and

three pulse midpoint converter configurations are as shown in Figure 1.

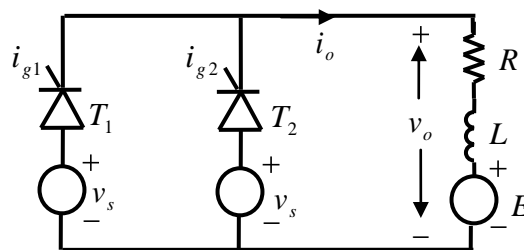


Figure 1: Two Pulse Midpoint Positive Converter.

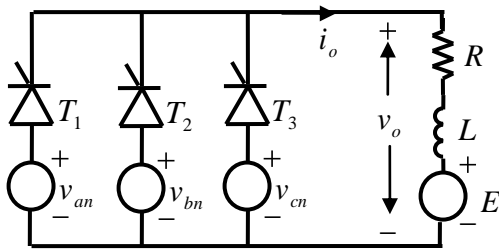
Where the two sources are displaced by angle  $\pi$ . The source relationships are:

$$\begin{aligned} v_s &= V_m \sin \omega t \\ -v_s &= -V_m \sin \omega t = V_m \sin(\omega t - \pi) \end{aligned} \quad (2)$$

$N_p$  is two in eqn 1, so for the two pulse midpoint converter the zero point of the control delay angle is zero.

$$\omega t|_{\alpha=0} = \omega t_a = 0 \quad (3)$$

For the three phase supply, the three pulse midpoint positive converter is shown below.



**Figure 2:** Three Pulse Midpoint Positive Converter.

The three phase voltage is represented as:

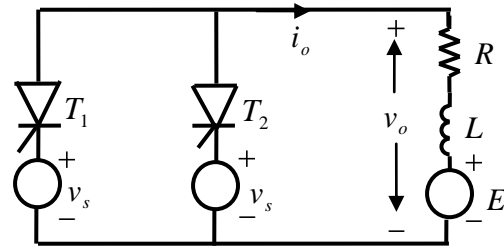
$$\begin{aligned} v_{an} &= V_m \sin \omega t \\ v_{bn} &= V_m \sin(\omega t - \frac{2\pi}{3}) \\ v_{cn} &= V_m \sin(\omega t - \frac{4\pi}{3}) \end{aligned} \quad (4)$$

$N_p = 3$  in Equation 1, so for the three pulse midpoint converter the zero point of the control delay angle is  $\pi/6$ .

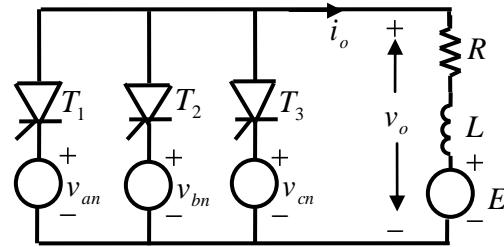
$$\omega t|_{\alpha=0} = \omega t_a = \frac{\pi}{6} \quad (5)$$

These are the practical midpoint phase controlled converters since we have single phase and three phase systems in the utility supply.

If the active switches are turned around to have cathode point at the positive terminal of the voltage supply, then we have negative AC to DC converters as shown below for the two and three pulse configurations.



**Figure 3:** Two Pulse Midpoint Negative Converter.

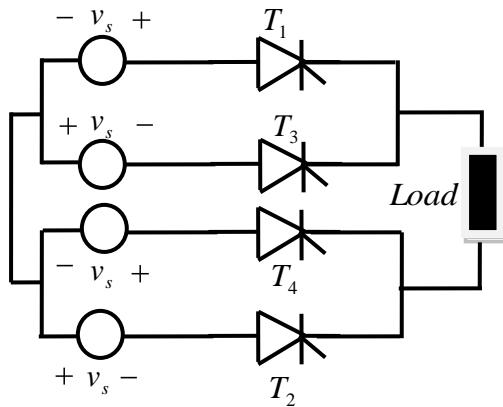


**Figure 4:** Three Pulse Midpoint Negative Converter.

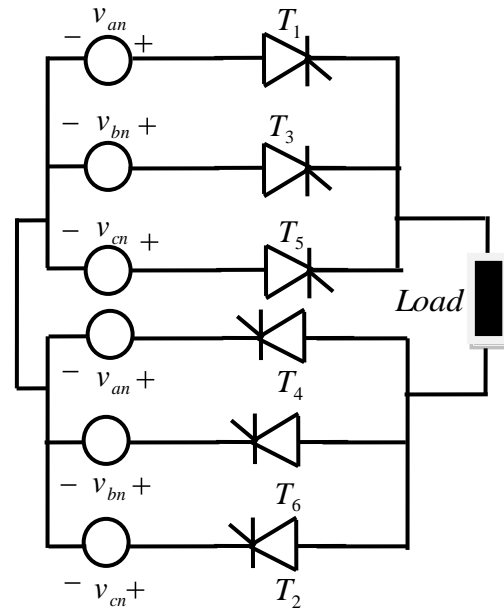
## THE FULLY CONTROLLED FULL BRIDGE CONVERTERS

Although the midpoint AC to DC converter is the basic building block for realizing other converter types, its application in industry is limited because of the severe problems associated with the presence of DC current in the AC input lines and the enormous effort it takes in terms of providing reactive components/equipment to solve the associated problems.

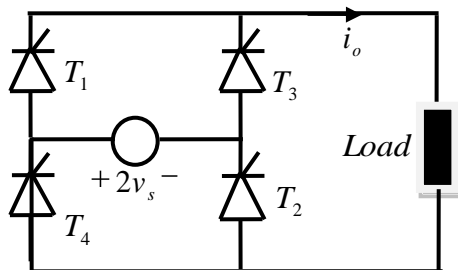
The concept of full bridge converter usually made-up of one positive and one negative converter supplying differential output voltage to the common load. The circuit configurations are show below.



**Figure 5a:** Two Pulse Full Bridge Converter  
This Circuit is Analytically Equivalent to the Figure 5b Below.

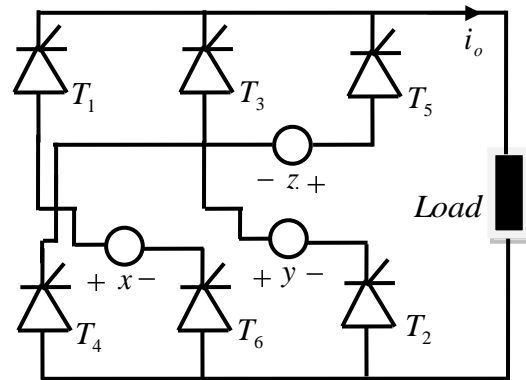


**Figure 6a:** Three Phase Full Bridge Converter  
The Figure 6a modifies to:

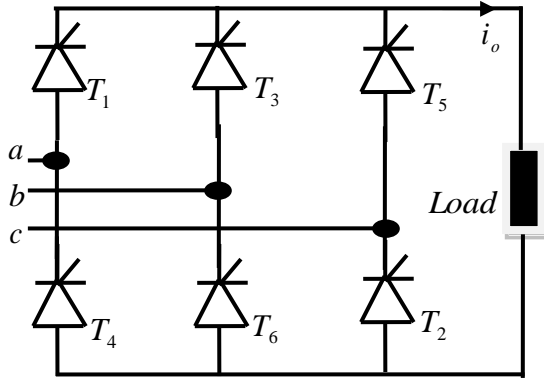


**Figure 5b:** Analysis Circuit of Two Pulse Full Bridge Converter.

Similar argument can be made for three phase full bridge converter as shown in the figures below.



**Figure 6b:** Three Phase Full Bridge Converter  
A Typical Representation of the Above Circuit is Shown Below.



**Figure 6c:** Analysis Circuit of Three Phase Full Bridge Converter

Where,

$$x = V_{an} - V_{bn} = V_{ab} = V_m \sin \omega t - V_m \sin(\omega t - \frac{2\pi}{3})$$

$$= \sqrt{3}V_m \sin(\omega t + \frac{\pi}{6}) \quad (6a)$$

$$y = V_{bn} - V_{cn} = V_{bc} = V_m \sin(\omega t - \frac{2\pi}{3}) - V_m \sin(\omega t - \frac{4\pi}{3})$$

$$= \sqrt{3}V_m \sin(\omega t - \frac{\pi}{2}) \quad (6b)$$

$$z = V_{cn} - V_{an} = V_{ca} = V_m \sin(\omega t - \frac{4\pi}{3}) - V_m \sin \omega t$$

$$= \sqrt{3}V_m \sin(\omega t - \frac{7\pi}{6}) \quad (6c)$$

Negative converters are obtained in the full bridge configuration by turning the inverter upside down or by reversing the polarity of all the switches thereby shifting the respective signals by  $\pi$ .

### OPERATIONAL ANALYSIS OF PHASE CONTROLLED AC TO DC CONVERTERS

The  $N_p$  pulse phase controlled AC to DC converter operates in two current conduction modes: Discontinuous Current Mode and Continuous Current Mode. In most cases, the conduction mode is continuous load current, hence this work emphasizes only on this mode of operation.

### Midpoint Converters

For the midpoint converter at continuous load current mode, the converter output voltage  $v_o$  can be given as:

$$v_o = \sum_{n=jN_p | j=1,2,3,\dots}^{\infty} (a_n \cos n\omega t + b_n \sin n\omega t) + V_{oo} \quad (7)$$

Where  $N_p$  is the output pulse number for the midpoint converter and  $V_{oo}$  is the average output voltage. When generally analyzed, Equation 7 can be simplified as:

$$v_o = V_{odmn} [\cos \alpha + \sum_{n=jN_p | j=1,2,3,\dots}^{\infty} V_{opn}] \quad (8)$$

For positive midpoint converter where  $V_{odmn}$  is the maximum value of average voltage  $V_{oo \max}$ ,

$$V_{odmn} = V_{oo \max} = \frac{N_p V_{mn}}{\pi} \sin \frac{\pi}{N_p} \quad (9)$$

Where,  $\alpha$ , is the control delay angle and  $V_{mn}$  is the amplitude of the AC input per cycle. The  $n^{th}$  harmonic amplitude for positive midpoint converter for n even is derived as:

$$V_{opn} = c_n \sin(n\omega t + \theta_n) \quad (10a)$$

And for n odd is derived as:

$$V_{opn} = -c_n \cos(n\omega t + \theta_n) \quad (10b)$$

Where  $\theta_n$  is the  $n^{th}$  harmonic voltage phase angle while

$$c_n = \left[ \frac{1}{(n+1)^2} + \frac{1}{(n-1)^2} - \frac{2}{(n+1)(n-1)} \cos 2\alpha \right]^{1/2} \quad (11)$$

For negative midpoint converters,  $v_o$  can be simplified as:

$$v_o = V_{odmn} \left[ -\cos\alpha + \sum_{n=jN_p}^{\infty} V_{onn} \right] \quad (12)$$

The  $n^{\text{th}}$  harmonic amplitude for negative midpoint converter for n even is derived as:

$$V_{onn} = -c_n \sin(n\omega t + \theta_n) \quad (13a)$$

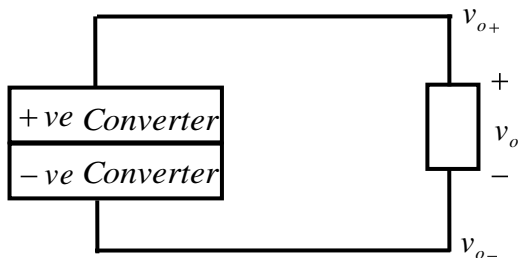
And for n odd is derived as:

$$V_{onn} = -c_n \cos(n\omega t + \theta_n) \quad (13b)$$

Where  $V_{odmn}$ ,  $\alpha$ , and  $c_n$  are as earlier defined.

### Full Bridge Converter

Full bridge AC to DC converters are made-up of positive and negative midpoint converters as shown below.



**Figure 7:** Conceptual Circuit of Full Bridge AC to DC Converter.

Where,

$$v_o = v_{o+} - v_{o-} \quad (14)$$

$v_{o+}$  and  $v_{o-}$  are obvious from the figure above as the output voltage of the positive and the negative converters respectively. From the above analysis for the positive and the negative midpoint converters,

$$v_o = V_{odmn} \left[ \left\{ \cos\alpha + \sum_{n=jN_p}^{\infty} V_{opn} \right\} - \left\{ -\cos\alpha + \sum_{n=jN_p}^{\infty} V_{onn} \right\} \right] \quad (15a)$$

$$v_o = V_{odmn} \left[ \left\{ 2\cos\alpha + \sum_{n=jN_p}^{\infty} (V_{opn} - V_{onn}) \right\} \right] \quad (15b)$$

It is to be noted that the magnitude of DC component  $|V_{odmn} \cos\alpha|$  for either positive or negative midpoint converters is doubled in the full bridge converter to become  $|2V_{odmn} \cos\alpha|$ .

The  $n^{\text{th}}$  harmonic amplitude for the full bridge converter is:

$$V_{onf} = V_{opn} - V_{onn} \quad (16)$$

For n even,

$$= c_n [\sin(n\omega t + \theta_n) + \sin(n\omega t + \theta_n)] \quad (17a)$$

$$= 2c_n \sin(n\omega t + \theta_n) \quad (17b)$$

### For n odd

$$V_{onf} = c_n [-\cos(n\omega t + \theta_n) + \cos(n\omega t + \theta_n)] = 0 \quad (18)$$

The implication of this is that the full bridge configuration eliminates odd harmonics even when present in the midpoint converters that make it up, but doubles the amplitude of the even harmonics.

For the full bridge converter, the maximum value of average voltage:

$$V_{oo\max} = 2V_{odmn} = \frac{2V_{mn} N_p}{\pi} \sin \frac{\pi}{N_p} \quad (19)$$

Parallel operation of full bridge converters is also obtainable to achieve 12-pulse and, indeed, other multipulse converter configurations. A freewheeling diode can also be connected across the converter load.

### **SIMPLORER® SIMULATION OF SAMPLE AC TO DC CONVERTERS UNDER DIFFERENT OPERATION CONDITIONS**

SIMPLORER®, a trademark of Ansoft Corporation, is a simulation package for electric circuit simulations that allows you to easily and quickly model all components of your application. You can design and model with electric and electronic facts; control and mechanical components; discontinuous processes; and controls with electric circuits, block diagrams, and state graph components.

The task of simulation using SIMPLORER® involves creation of project using SSC Commander, creation of model using the graphical input tool schematic or the SIMPLORER® text editor, evaluation and analysis of result using the simulator data and Day Post Processor applications, respectively

In this section, various configurations of AC to DC converter are simulated using Ansoft SIMPLORER® for the two-pulse, three pulse, and the six-pulse converter. Both the positive converter and the negative converter arrangements are investigated.

#### **Simulation Task**

For control delay angle  $\alpha = 0$  and  $\alpha = \frac{\pi}{3}$

display output voltage  $v_o$  for:

- a. Two-pulse AC/DC converter (input  $v_s = 230\sqrt{2} \sin \omega t$  where  $f = 50\text{Hz}$  for both positive and negative converters.

- b. Three pulse AC/DC converter (positive and negative) with

$$v_{an} = 230\sqrt{2} \sin \omega t$$

$$v_{bn} = 230\sqrt{2} \sin(\omega t - \frac{2\pi}{3})$$

$$v_{cn} = 230\sqrt{2} \sin(\omega t - \frac{4\pi}{3})$$

- c. Six pulse (3-phase full bridge) both positive and negative with input as

$$v_{ab} = 415\sqrt{2} \sin \omega t$$

$$v_{bc} = 415\sqrt{2} \sin(\omega t - \frac{2\pi}{3})$$

$$v_{ca} = 415\sqrt{2} \sin(\omega t - \frac{4\pi}{3})$$

- I. The load is  $50\Omega$  resistor with both positive and negative converter
- II. Series combination of  $10\Omega$  resistor,  $60\text{mH}$  inductance, and  $120\text{V}$  EMF with positive converter only.

In each case, the output voltage of the desired load is the parameter of interest.

## Simulation Results

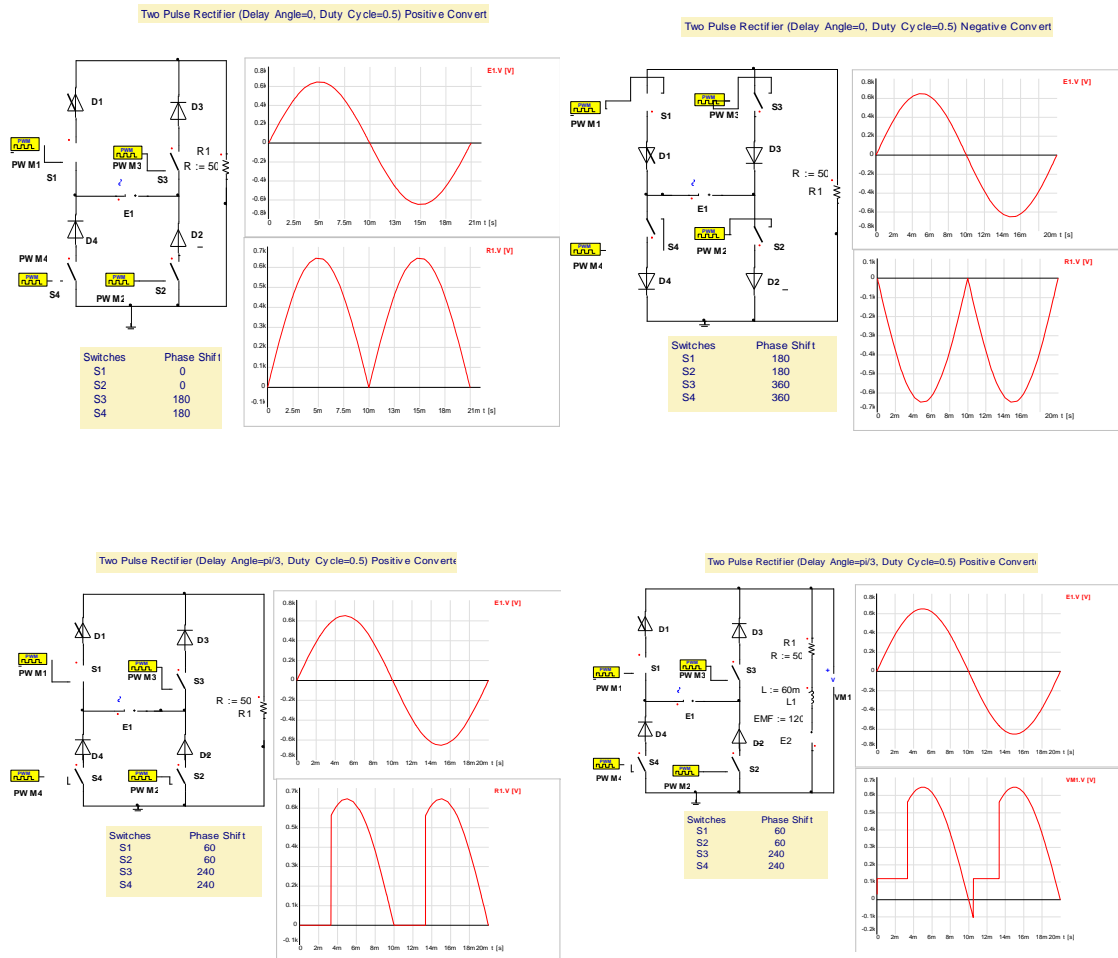
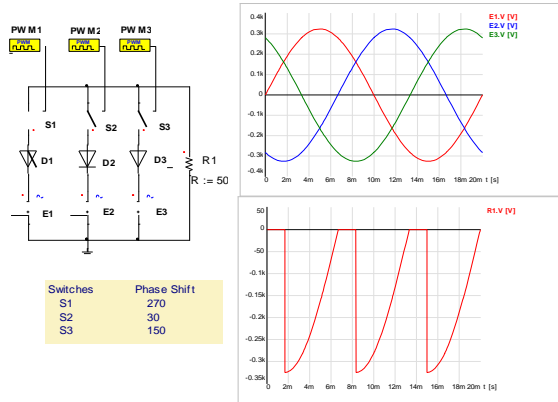
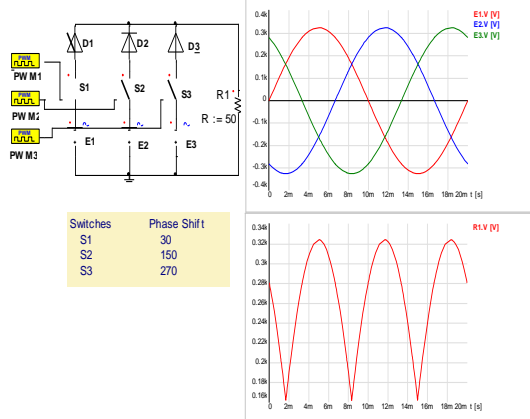


Figure 8: Simulation Results for Sample Two Pulse AC to DC Converters.

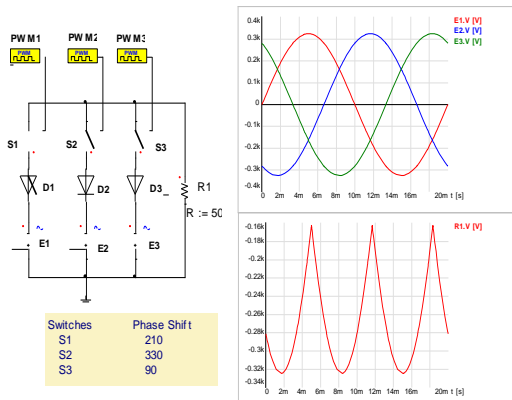
Three Pulse AC/DC Converter (Delay Angle= $\pi/3$ , Duty Cycle=1/3) Negative Converter



Three Pulse AC/DC Converter (Delay Angle=0, Duty Cycle=1/3) Positive Converter



Three Pulse AC/DC Converter (Delay Angle=0, Duty Cycle=1/3) Negative Converter



Three Pulse AC/DC Converter (Delay Angle= $\pi/3$ , Duty Cycle=1/3) Positive Converter

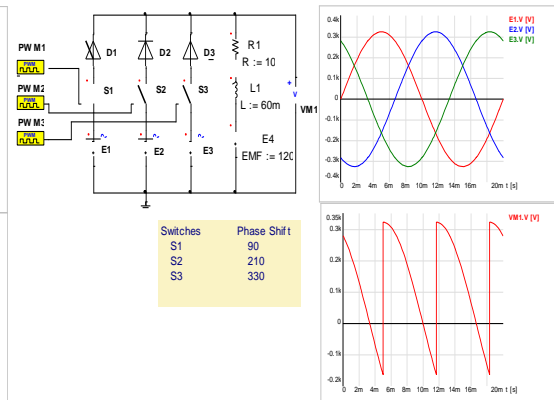


Figure 9: Simulation Results for Sample Three Pulse AC to DC Converters.



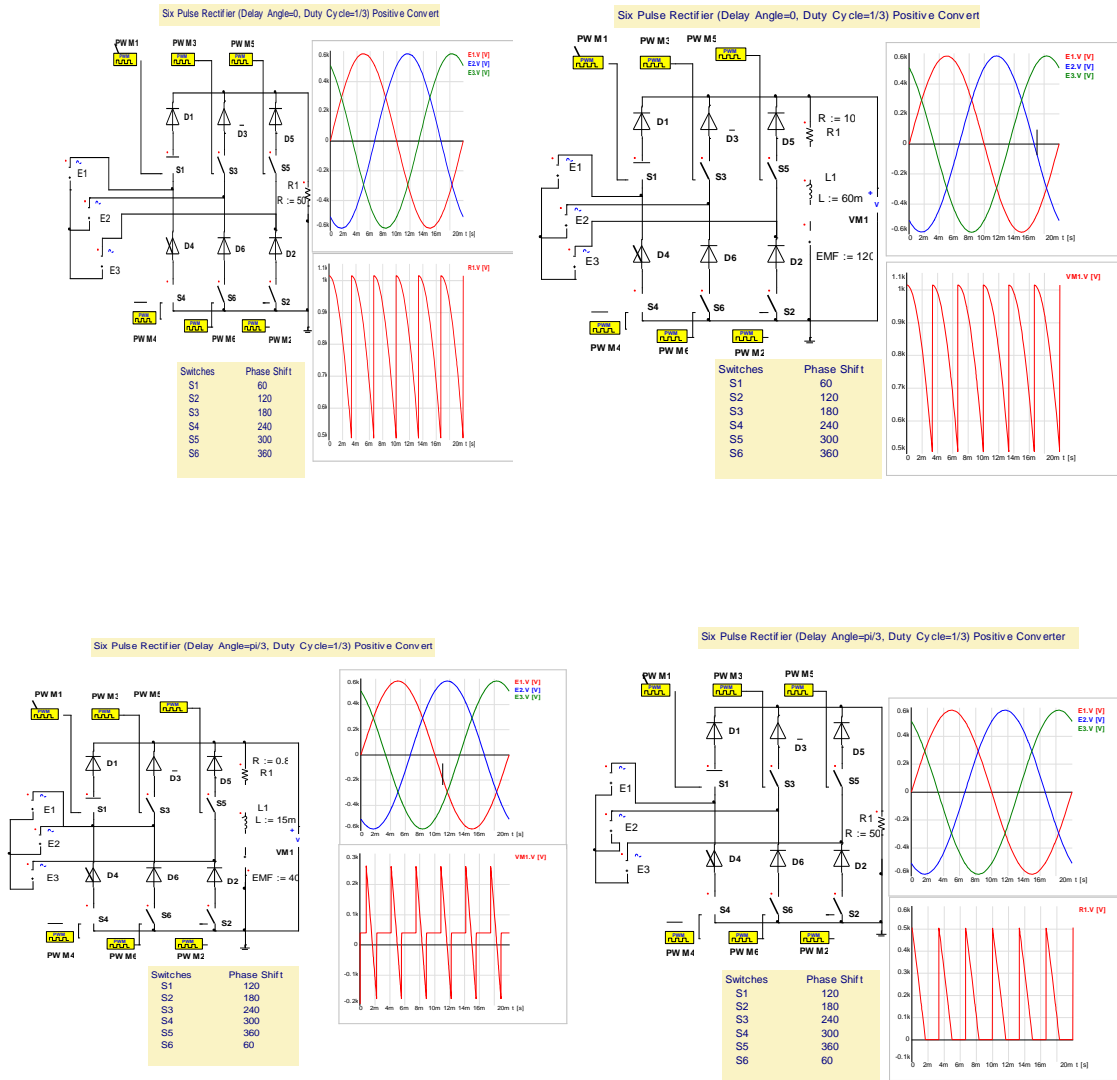


Figure 10: Simulation Results for Sample Six Pulse AC to DC Converters.

## CONCLUSION

A detailed and an insightful analysis of controlled AC to DC converters operating under continuous load current have been presented in this paper. The derived equations, in general form, can be used for a phase controlled AC to DC converter of any output voltage pulse number and therefore of any AC input phase number.

It can be seen from the simulation results of figures 8 to 10 that for any given control delay angle  $\alpha$  the outputs of the negative converters are shifted by  $180^\circ$  in phase from the output of the corresponding positive converters and that the positive converters have an average positive output voltage while the negative converters have an average negative output voltage. The output pulse numbers of 2, 3, and 6 are also observed in Figures 8, 9, and 10, respectively.

The energy storage ability of the inductors is also evident in the circuit configuration with RLE loads where the output voltage has both the positive and the negative components; this is very much in accordance with relevant theory. Note is also taken that the output voltage is at a constant value of E or zero in the RLE or R load configurations respectively throughout the delay period.

The analysis results can be used to predict the output performance of any standard phase controlled converter application circuit with any given number of AC input phases and/or output pulses under continuous load current. The software for simulation, Ansoft SIMPLORER<sup>®</sup>, is demonstrated to be very useful for the purpose of simulation of power electronic circuits and systems. It is therefore, highly, recommended that researchers and students of power electronic should utilize this software in the design process of power electronic circuits.

## REFERENCES

1. Agu, M.U. 1997. "A Generalized Conceptual Analysis of Phase-Controlled AC to DC Converters Under Continuous Load Current Mode". Electric Power Engineering Conference (EPEC97): University of Nigeria, Nsukka. 119-129.
2. Ming-Tsung, T. and W.I. Tsai. 1999. "Analysis and Design of Three-Phase AC-to-DC Converters With High Power Factor and Near-Optimum Feedforward". *IEEE Transactions on Industrial Electronics*. 46(3):535-543.
3. Dewan, S.B. and A. Straughen. 1978 *Power Semiconductor Circuits*. John Wiley: New York, NY.
4. Machhopadhyay, S. 1978. "A New Concept for Improving the Performance of Phase Controlled Converters". *IEEE Trans. on Indu. Appl.* 1A(14):594-603.
5. Dubey, G.K., S.R. Doradla, A. Joshi, and R.M.K. Sinha. 1986. *Thyristorized Power Controllers*. Wiley Eastern: Delhi, India.
6. Agu, M.U. 2008 "Advanced Power Electronic EEE 612". Unpublished Lecture Notes, Department of Electrical Engineering University of Nigeria, Nsukka.

## ABOUT THE AUTHORS

**Engr. Cosmas Uchenna Ogbuka**, received his B.Eng. (First Class Honors) and M.Eng. Degrees (Distinction) in 2004 and 2009, respectively, in the Department of Electrical Engineering University of Nigeria, Nsukka where he presently works as a Lecturer/Research Student. His research interests are in adjustable speed drives, microgrids, power electronics, and dispersed generation.

**Engr. Prof. Marcel U. Agu**, obtained his B.Sc. in Electrical Engineering in 1974 in the University of Nigeria, Nsukka. He also received his M.A.Sc. and Ph.D. in 1978 and 1982, respectively, in Power Electronics from the University of Toronto Canada. He is a Professor in the Department of Electrical Engineering University of Nigeria, Nsukka. His research interests are in power electronic circuits and electric drives.

## SUGGESTED CITATION

Ogbuka, C.U. and M.U. Agu. 2010. "Continuous Load Current Mode Analysis of Phase-Controlled AC to DC Converters." *Pacific Journal of Science and Technology*. 11(2):91-100.

 [Pacific Journal of Science and Technology](http://www.akamaiuniversity.us/PJST.htm)